



Axio Power Canada Inc./
SunEdison Canada

Project Description Report

For

Norfolk Bloomsburg TS
Solar Energy Project

H335467
Rev. 5
November 25, 2011

Report Disclaimer

This report has been prepared by Hatch Ltd. for the sole and exclusive use of Axio Power Canada Inc./ SunEdison Canada (the "Client") for the purpose of assisting the Client in making decisions with respect to the development of a proposed solar photovoltaic project and shall not be (a) used for any other purpose, or (b) provided to, relied upon or used by any third party.

This report contains opinions, conclusions and recommendations made by Hatch Ltd. (Hatch), using its professional judgment and reasonable care. Any use of or reliance upon this report by the Client is subject to the following conditions:

- the report being read in the context of and subject to the terms of the agreement between Hatch and the Client including any methodologies, procedures, techniques, assumptions and other relevant terms or conditions that were specified or agreed therein;
- the report being read as a whole, with sections or parts hereof read or relied upon in context;
- the conditions of the site may change over time (or may have already changed) due to natural forces or human intervention, and Hatch takes no responsibility for the impact that such changes may have on the accuracy or validity of the observations, conclusions and recommendations set out in this report; and
- the report is based on information made available to Hatch by the Client or by certain third parties; and unless stated otherwise in the Agreement, Hatch has not verified the accuracy, completeness or validity of such information, makes no representation regarding its accuracy and hereby disclaims any liability in connection therewith.

November 25, 2011

Axio Power Canada Inc./SunEdison Canada Norfolk Bloomsburg TS - Solar Energy Project

Project Description Report

Table of Contents

Report Disclaimer

1. Introduction	1
1.1 General	1
1.2 Renewable Energy Approval Legislative Requirements	1
1.3 Purpose of Report	2
1.4 Formal Revisions to this Report	2
2. General Information Requirements.....	3
2.1 General Information.....	3
2.2 Contacts.....	3
2.3 Authorizations Required.....	4
2.4 Federal Involvement.....	4
2.5 Supporting Reports.....	4
3. Project Information.....	7
3.1 Ownership of the Land.....	7
3.2 Energy Sources to Generate Electricity	7
3.3 Nameplate Capacity.....	7
3.4 Class of the Renewable Energy Facility.....	7
3.5 Project Components.....	7
3.6 Project Activities	10
3.6.1 Construction.....	10
3.6.1.1 Site Survey and Staking.....	10
3.6.1.2 Site Preparation	10
3.6.1.3 Access Road Construction	10
3.6.1.4 Installation of Foundations and Support Structures.....	10
3.6.1.5 Installation of PV Modules and Mounting Racks	11
3.6.1.6 Installation of Inverters and Pad-Mounted Transformers.....	11
3.6.1.7 Electrical Cable Installation.....	11
3.6.1.8 Switch House Yard Construction	11
3.6.1.9 Electrical Distribution Line Installation and Interconnection Point.....	11
3.6.1.10 Testing and Commissioning.....	12

3.6.1.11	Site Restoration.....	12
3.6.2	Operation and Maintenance.....	12
3.6.2.1	Operation.....	12
3.6.2.2	Site Inspection and Maintenance.....	13
3.6.2.3	Storm Water Management.....	14
3.6.2.4	Water Supply Facilities.....	14
3.6.2.5	Wastewater (Sewage) Facilities.....	15
3.6.2.6	Waste Disposal Facilities.....	15
3.6.2.7	Exhaust Equipment.....	15
3.6.3	Decommissioning.....	15
4.	Description of Environmental Effects.....	16
4.1	General.....	16
4.2	Environmental Resource Features and Potential Effects.....	17
4.2.1	Heritage and Archaeological Resources.....	17
4.2.2	Natural Heritage Resources.....	17
4.2.3	Waterbodies.....	18
4.2.4	Air, Odour and Dust.....	19
4.2.5	Noise.....	19
4.2.6	Land Use and Resources.....	19
4.2.7	Provincial and Local Infrastructure.....	20
4.2.8	Public Health and Safety.....	20
4.2.9	Areas Protected Under Provincial Plans and Policies.....	21
4.3	Summary.....	21
5.	References.....	26

List of Tables

Number	Title
Table 4.1	Summary of Potential Negative Environmental Effects during Construction, Operations and Decommissioning

List of Figures

Number	Title
Figure 2.1	Site Layout Plan
Figure 3.1	Generalized Schematic of Electrical Equipment Connectivity
Figure 3.2	Photo of Typical Solar PV Module Installation

1. Introduction

1.1 General

Axio Power Canada Inc./SunEdison Canada (“Axio/SunEdison”) is proposing to develop a 10-megawatt (MW) solar photovoltaic (PV) project titled Norfolk Bloomsburg TS Solar Energy Project (the “Project”). The Project Location¹ is situated on approximately 29 hectares (ha) of land on Part of Lots 3 and 4, Concession 12, Norfolk County (single tier municipality).

The Project is proposed to be constructed on privately owned land currently used for agricultural crops. The Project is located about 1 km south of the Village of Bloomsburg and about 4 km northeast of the Town of Simcoe. Local roads include Stone Quarry Road (Concession 13 Townsend Road) and Cloet Road immediately south and west of the Project Location, respectively.

The proposed Project is a renewable energy generation facility which will use solar photovoltaic technology to generate electricity. Electricity generated by solar photovoltaic panels will be converted from direct current (DC) to alternating current (AC) by inverters and then stepped-up to a voltage of 27.6 kV via pad-mounted transformers prior to being connected to the existing local distribution line. In order to meet the Ontario Power Authority (OPA)’s Feed-In-Tariff (FIT) Program requirements, a specific percentage of equipment will be manufactured in Ontario.

The construction of the Project will begin once the Renewable Energy Approval (REA) has been obtained. The construction period is estimated to be approximately 8 months, with Project commissioning anticipated in October 2012. Operationally, the lifespan of the Project will be at least 20 years, which can be extended up to 30 years or more with proper maintenance, component replacement and repowering.

1.2 Renewable Energy Approval Legislative Requirements

Ontario Regulation (O. Reg.) 359/09 – *Renewable Energy Approvals Under Part V.0.1 of the Act*, (herein referred to as the REA Regulation), came into force on September 24, 2009 and identifies the Renewable Energy Approval (REA) requirements for renewable energy generation facilities in Ontario. The REA Regulation has since been amended by O. Reg. 521/10, which came in effect as of January 1, 2011. As per the REA Regulation (Part II, Section 4), ground mounted solar facilities with a name plate capacity greater than 12 kilowatts (kW) are classified as Class 3 solar facilities and require an REA.

Section 13 of the REA Regulation requires proponents of Class 3 solar projects to prepare a Project Description Report. As prescribed by Table 1 of O. Reg. 359/09, the Project Description Report shall describe the following:

1. *“Any energy sources to be used to generate electricity at the renewable energy generation facility.*

¹ “Project Location means, when used in relation to a renewable energy project, a part of land and all or part of any building or structure in, on or over which a person is engaging in or proposes to engage in the project and any air space in which a person is engaging in or proposed to engage in the project” (O. Reg. 359/09, s. 1 (1)).

2. *The facilities, equipment or technology that will be used to convert the renewable energy source or any other energy source to electricity.*
3. *If applicable, the class of the renewable energy generation facility.*
4. *The activities that will be engaged in as part of the renewable energy project.*
5. *The name plate capacity of the renewable energy generation facility.*
6. *The ownership of the land on which the Project Location is to be situated.*
7. *Any negative environmental effects that may result from engaging in the project.*
8. *An unbound, well marked, legible and reproducible map that is an appropriate size to fit on a 215 mm by 280 mm page, showing the Project Location and the land within 300 m of the Project Location."*

A draft of the Project Description Report must be made available to the public, the local municipality and identified Aboriginal communities at least 60 days prior to the first and final public consultation meetings in accordance with O. Reg. 359/09.

1.3 Purpose of Report

The Project Description Report is one of the first Project documents prepared once the REA process commences and serves several purposes. Initial drafts of the Report were used to provide preliminary information regarding the Project to the public, Aboriginal groups, municipalities and other government agencies. As the REA process progressed, the Report was updated based on information obtained from various studies and data collection activities as well as preliminary planning and engineering of the Project. As a consequence, the final version of the Report serves as a comprehensive overview document that summarizes all of the important information about the Project.

Section 2 of the Report describes general information about the Project including the Project name, location and contact information. Section 3 describes the Project components, the major construction activities, operational aspects and decommissioning. Section 4 describes the potential environmental effects associated with the Project's construction, operation and decommissioning phases and the proposed mitigation measures to prevent/minimize those effects. Section 5 provides the references.

This Project Description Report has been prepared in accordance with the requirements identified in Table 1 of O. Reg. 359/09, as well as the guidance provided in the Ministry of the Environment's (MOE) Draft Technical Bulletin 1 – Guidance for Preparing the Project Description Report as part of an application under O. Reg. 359/09 (MOE, 2010).

1.4 Formal Revisions to this Report

The following formal revisions of this report have taken place:

- Revision 0, July 16, 2010 – Original draft issued in advance of first public meeting.
- Revision 3, June 1, 2011 – Revised draft issued in advance of final public meeting.
- Revision 4, August 25, 2011 – Revised draft issued after final public meeting.
- Revision 5, November 25, 2011 – Final report.

2. General Information Requirements

2.1 General Information

The name of the Project is the Norfolk Bloomsburg TS Solar Energy Project (the "Project").

The Project Location, per the definition in the REA Regulation, is shown in Figure 2.1. The Project Location includes the entire footprint of the project, including all temporary and permanent parts of the land that will be utilized for the Project. This includes the following Project features:

- all areas where vegetation will be cleared
- temporary and permanent site access roads
- solar panel arrays
- inverters/pad-mounted transformer in building enclosures
- switch house yard and communication tower
- temporary laydown area for construction
- project fencing
- electrical distribution line from the switch house yard to the interconnection point.

2.2 Contacts

Axio Power Canada Inc./SunEdison Canada is the proponent of the Project. The contact information is as follows:

Rob Miller
Director of Development
SunEdison
945 Princess Street, Suite 252
Kingston, ON, K7L 3N6
Tel: 613-545-0215
Fax: 613-545-0692
Email: rmiller@sunedison.com

Hatch Ltd. (Hatch) has been retained to assist Axio/SunEdison in meeting the REA requirements. Contact information for Hatch is as follows:

Bruce G. Bennett, M.Sc., P.Geo.
Environmental Coordinator
Hatch Ltd.
4342 Queen Street, Suite 500
Niagara Falls, ON, L2E 7J7
Tel: 905-357-6988
Fax: 905-374-1157
Email: bbennett@hatch.ca

2.3 Authorizations Required

Permits, licenses and authorizations such as those listed below, in addition to the REA may be required for the Project to proceed:

- Entrance Permit – Norfolk County will likely require an entrance permit for the site access entrance to be constructed from Stone Quarry Road.
- Building Permit – Norfolk County may require a building permit for construction.

2.4 Federal Involvement

No Federal lands or resources will be utilized for the Project and based on the resources within the Project Location, issues under Federal jurisdiction are not anticipated. Therefore, no Federal involvement (including permits and approvals) is required.

2.5 Supporting Reports

Several reports have been prepared as part of the REA application and are provided under separate cover. These reports provide detailed information on the various natural and socio-economic features on and within proximity to the Project Location. Some of the reports include an assessment of the potential effects of the Project's construction, operation and decommissioning phases along with recommended mitigation measures to ensure that there will be no significant negative effects.

These reports should be referred to by persons seeking further detailed information.

- **Natural heritage features** can be found in the Natural Heritage Assessment Records Review Report (Hatch, 2011a), Natural Heritage Assessment Site Investigation Report (Hatch, 2011b) Natural Heritage Assessment Evaluation of Significance Report (Hatch, 2011c), Natural Heritage Assessment Environmental Impact Study Report (Hatch, 2011d).
- **Waterbodies** can be found in the Water Body Records Review Report (Hatch, 2011e) and the Water Body Site Investigation Report (Hatch, 2011f).
- **Construction, operation and decommissioning** activities and timelines, facilities components, environmental effects, mitigation and monitoring can be found by Project phase in the Construction Plan Report (Hatch, 2001g), the Design and Operations Report (Hatch, 200h) and the Decommissioning Plan Report (Hatch, 2011i).
- **Socio-economic conditions** (e.g. land use, municipal infrastructure) are discussed in this report.
- **Protected properties and heritage resources** are discussed in this report.
- **Noise conditions** including the noise sources associated with the Project electrical equipment (inverters, transformers), noise receptors and the simulation results of noise modeling of the Project during its operation can found in the Noise Study Report (Hatch, 2011j).
- **Archaeological resources** and an assessment of potential effects can be found in the Stage 1 and 2 Archaeological Assessment Report (TAI, 2010).
- **Geotechnical conditions** (e.g. soils, groundwater, bedrock) can be found in the Geotechnical Report (GENIVAR, 2011).

- **Storm water runoff conditions** (e.g. existing and proposed runoff peak flows) can be found in the Storm Water Management Report (McIntosh Perry, 2011a).
- **Traffic conditions** (e.g. road classifications, expected traffic volumes) can be found in the Traffic Impact Study Report (McIntosh Perry, 2011b).
- **Environmental conditions** and potential areas of environmental concern related to previous and current uses of the Project Location lands can be found in the Phase I Environmental Site Assessment Report (McIntosh Perry, 2011c).
- **Groundwater conditions** and existing water wells, including a proposed groundwater monitoring program can be found in the Proposed Groundwater Monitoring Scoping Report (McIntosh Perry, 2011d).
- **Reflectivity aspects** related to potential visual disturbance from reflections from the solar PV modules can be found in the Reflectivity Study Report (IBI, 2011).

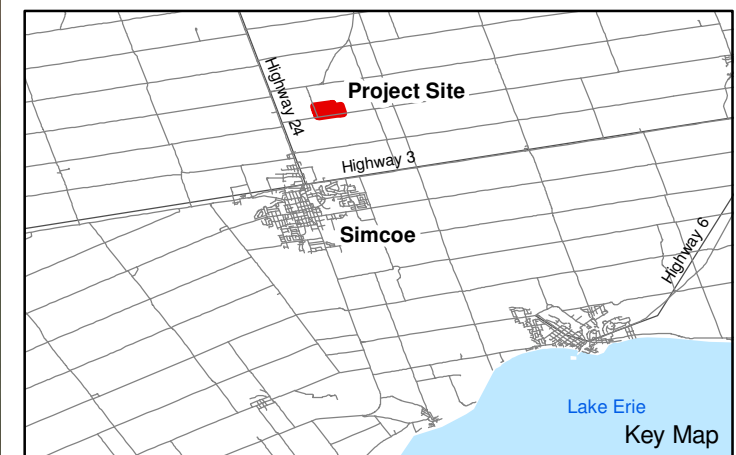
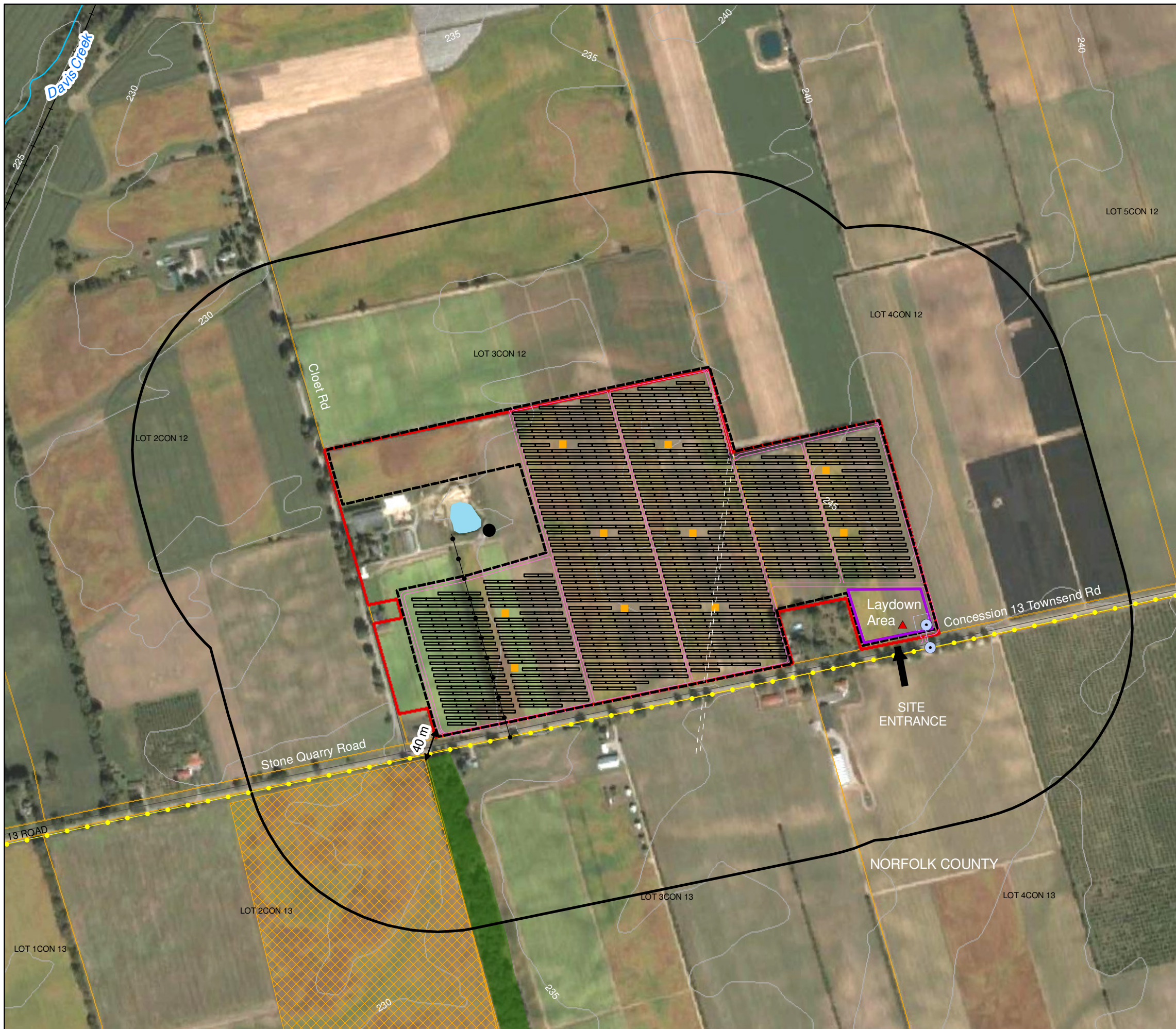

- LEGEND**
- Existing Features**
- Rogers Cell Tower (328 m)
 - Road
 - Topographic Contour (5 m interval)
 - Transmission Line
 - - - Non-operational Bell Cable (To be Removed)
 - Hydro Line (To be Relocated)
 - Watercourse
 - Dugout Pond
 - Parcel
 - 300 m from Project Location
 - Project Location
 - Project Site
- Significant Natural Features / Significant Wildlife Habitat**
- Tallgrass Prairie / Significant Wildlife Habitat (Area-sensitive Grassland Bird Species / Species of Conservation Concern)
 - Significant Woodland / Significant Wildlife Habitat (Forest Bird Species of Conservation Concern)
- Proposed Project Components**
- ▲ Communication Tower
 - Inverter
 - Switch House
 - Connection Point
 - Panel Layout
 - Access Roads
 - Fence
 - Transmission Line
 - Laydown Area
- Notes:
 1. OBM and NRVIS data downloaded from LIO, with permission.
 2. Spatial Referencing UTM NAD 83, August 2010.
 3. Satellite imagery from Google Earth Pro, April 2009.

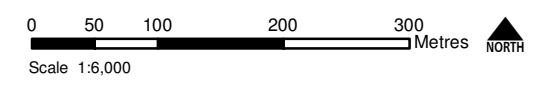

Figure 2.1
 Axiom Power Canada Inc./SunEdison Canada
Norfolk Bloomsburg TS Site Layout Plan

3. Project Information

The following sections are intended to satisfy the requirements of Table 1 in O. Reg. 359/09 (Section 10 – Project Description Report) and MOE Draft Technical Bulletin 1 (MOE, 2010). Further details on the Project are provided in other required reports as per O. Reg. 359/09, including the Construction Plan Report, Design and Operations Report and the Decommissioning Plan Report.

3.1 Ownership of the Land

The Project is located on privately owned lands. The Project Location is situated on approximately 29 hectares of land on Part of Lots 3 and 4, Concession 12, Norfolk County. The Civic Address is 48 Cloet Road, Simcoe County, Ontario. The legal description of the property that the Project Location is situated within is: Part Lot 3-4 Concession 12 Townsend as in NR374027 (Firstly and Secondly) & NR325643 except Part 1 37R1762; S/T NR246465, NR2466466; Norfolk, County.

3.2 Energy Sources to Generate Electricity

Solar energy will be used to generate electricity. No supplementary fuel sources are used in the generation of this renewable energy.

3.3 Nameplate Capacity

The nameplate capacity of the Project will be up to 10 MW AC. The project may be up to approximately 12.2 MW DC.

3.4 Class of the Renewable Energy Facility

The Project will be a Class 3 solar facility. That is, the Project is ground-mounted and greater than 12 kilowatts (kW).

3.5 Project Components

Figure 2.1 provides a conceptualized depiction of the Project including the Project Location boundaries, existing local roads, topographic contours, existing transmission line, land uses, natural features and waterbodies on and within 300 m of the Project Location. Also depicted are the Project components including the construction laydown area, access roads, solar PV module arrays, inverter/transformer clusters, switch house yard, and the connecting distribution line. Setback distances from identified significant natural heritage features and waterbodies are also shown.

The main components of the Project will include the following:

- Approximately 45,000 solar PV modules, each 265 to 295 watts (W) and weighing about 23 kg, with approximate dimensions of 1980 mm long by 990 mm wide by 50 mm thick.
- Twenty 500 kW (kilowatt) AC inverters that will convert the direct current supplied by the PV modules to alternating current. Ten pad-mounted 1MVA (Megavolt-ampere) three-phase, liquid-filled transformers that will 'step up' the voltage to 27.6 kV. Each installation will consist of a pair of 500 kW inverters and a single 1MVA pad-mounted transformer in one of ten building enclosures (E-House) to protect the equipment from the weather and to reduce noise emissions.

- A gravel switch house yard that will house the switchgear, control and monitoring equipment, and a communication tower.
- A paved site entrance road and several gravel interior access roads.
- Galvanized chain link fence around the perimeter of the Project Location and a gated entrance.
- A temporary laydown / staging area to be used for construction trailers, material and equipment storage and vehicle parking during construction of the Project.
- A surface water drainage system comprised of grassed swales, roadside ditches and culverts.

Figure 3.1 depicts a generalized schematic illustrating how electricity will be generated, inverted, transformed and transmitted by the electrical equipment used for the Project.

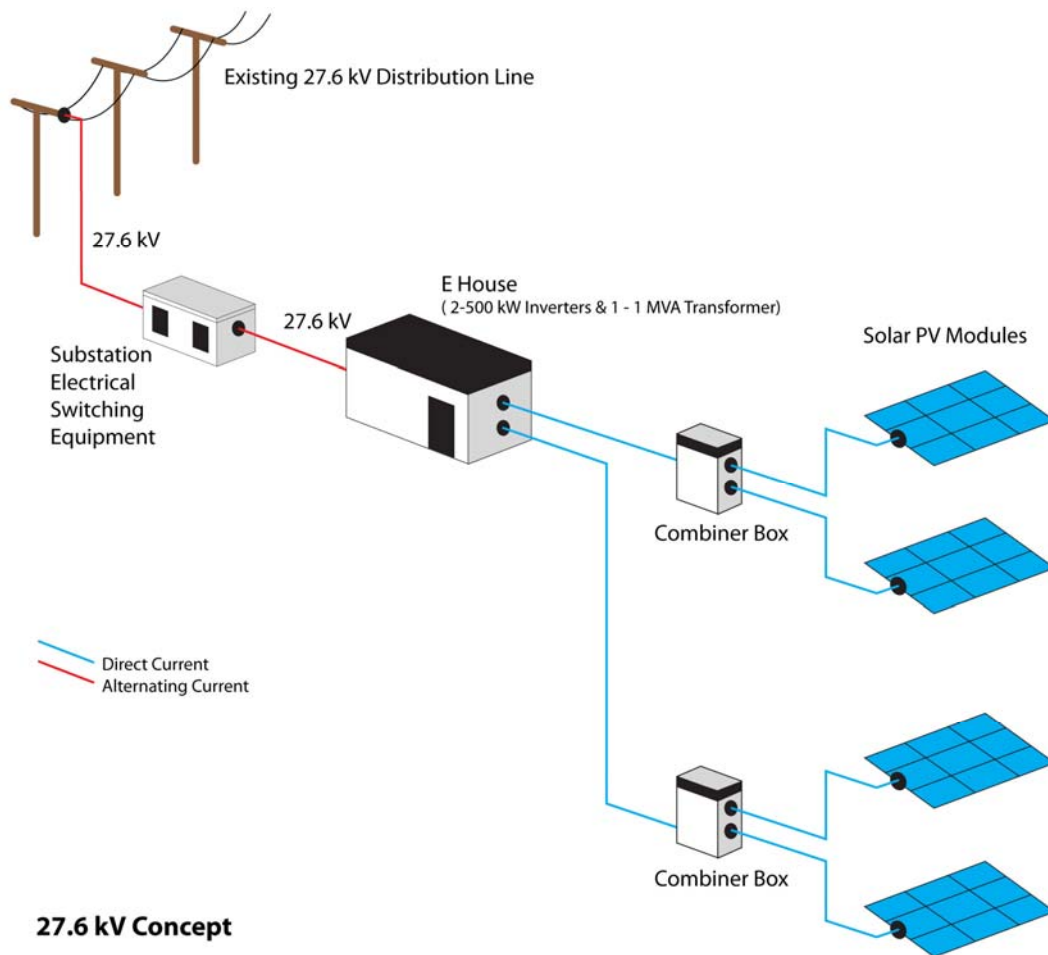

Figure 3.1 Generalized Schematic of Electrical Equipment Connectivity

Upon exposure to sunlight, the solar modules convert solar radiation into direct current (DC) electricity through a process referred to as the photovoltaic effect. This effect occurs when the sunlight energy is transferred to semiconductors in the modules, which creates a corresponding electric current. For the Project, the solar PV modules will be mounted on steel racks with a fixed tilt 30° angle facing south. Each rack will typically contain forty-four (44) 270 watt PV modules connected together by electrical wiring (Figure 3.2). The racks of modules will be arranged in long rows, typically spaced about 5.86 m apart.

The DC electrical current from the solar PV modules will be transmitted across the back of the modules and through underground wires connected to combiner boxes. The combiner boxes allow the connection of numerous incoming wires from the racks of modules into a single outgoing electrical cable. The DC electrical current from the combiner boxes will be transmitted through underground cabling connected to one of two 500 kW inverters housed in a building enclosure. Each inverter will convert the DC electrical current to alternating current (AC) and an inverter transformer will step-up the voltage to 27.6 kV.

The electricity, now at 27.6 kV (AC), will be transmitted through underground cabling to the electrical switching equipment situated in the switch house yard. Electricity will then flow from the switching equipment through overhead electrical lines and connect to the local distribution line at its existing voltage of 27.6 kV.



Figure 3.2 Photo of Typical Solar PV Module Installation

3.6 Project Activities

The Project activities involved in the construction, operation and decommissioning phases of the Project are outlined in the following sections. For Information regarding the construction, operation and decommissioning of these components, please refer to the Construction Plan Report, the Design and Operations Report, and the Decommissioning Report.

3.6.1 Construction

The construction period is estimated to be approximately 8 months. The initial site preparation activities are anticipated to begin in early January 2012 and be completed by end of March. Construction and installation activities are then anticipated to begin in April and continue to the end of September. Following testing and commissioning of the facilities, the Project is expected to achieve commercial operation by mid-October 2012.

3.6.1.1 Site Survey and Staking

An Ontario land surveyor will survey and stake the locations of the Project Location perimeter fencing, access roads and foundations as well as any buried utilities, infrastructure and associated easements. Any designated environmental features (e.g. waterbodies, woodlands) and their setbacks will be demarcated and protected by means of staking, flagging, fencing and signage to prevent any intrusion into these areas by construction vehicles.

3.6.1.2 Site Preparation

Prior to commencement of construction, sediment and erosion controls (e.g. silt fencing, rock flow check dams) will be installed throughout the Project Location in accordance with the Sediment and Erosion Control Plan (McIntosh Perry, 2011a). Trees and large standing vegetation will be cleared from areas where the photovoltaic arrays will be constructed. Meadow vegetation will be left in place to the extent possible. Where practical, merchantable timber, non-merchantable timber (e.g. firewood) and other cleared vegetation, along with any removed topsoil will be stockpiled adjacent to the access roads. Locations of topsoil, timber and vegetation stockpiles will be determined and not within 30 m of any identified waterbodies.

3.6.1.3 Access Road Construction

A new site access road, about 5 m wide, will be constructed of asphalt from Stone Quarry Road into the Project Location. In addition, several smaller gravel roads, about 3.7 m wide each, will be constructed within the interior areas of the Project Location. Road construction will involve vegetation clearing (if necessary) and topsoil removal prior to the placement of a granular base. Ditches and culverts will be constructed, as necessary, to maintain site drainage. Following construction, any access roads that are not required will be removed and restored by replacing the topsoil and seeding the area.

3.6.1.4 Installation of Foundations and Support Structures

Foundations will be installed beneath each inverter/transformer cluster (i.e., building enclosures) and support structures installed to support the PV modules and their mounting racks. Detailed design of the foundations and support structures is yet to be completed, however, it is expected that the foundations for the inverters and pad-mounted transformers will be precast concrete pads. The module racks are expected to be supported by steel piles, driven or screwed into the ground. An

estimated 5,000 piles will be installed within the Project Location to support the racking structures and the PV modules. Foundation construction and the installation of support structures will be inspected prior to the installation of PV modules and wiring.

3.6.1.5 *Installation of PV Modules and Mounting Racks*

The solar PV modules will be mounted on a fixed tilt, ground mounted racking system comprised of a steel and/or aluminum lattice structure. Each lattice structure will be assembled on-site and will typically hold 44 individual PV modules. The modules will be mounted on the racking system by installers with the help of a small mobile crane. The racking system will be supported by steel uprights mounted on steel piles. An estimated 1030 racks will be required for the Project.

3.6.1.6 *Installation of Inverters and Pad-Mounted Transformers*

The Project will have a total of twenty 500 kW AC inverters and ten intermediate 1 MVA pad-mounted transformers. The inverters will convert the DC power collected by the solar PV modules into AC power and this voltage will be stepped up by the pad-mounted transformers to a voltage of 27.6 kV. Each inverter/transformer cluster installation will consist of two 500 kW inverters and a single 1MVA pad-mounted transformer installed together in one of ten prefabricated buildings to protect the equipment from the weather and to reduce noise emissions. The inverters, transformers and prefabricated building enclosures will be trucked to the site and installed on either a precast or cast-in-place concrete pad by means of a crane.

3.6.1.7 *Electrical Cable Installation*

Trenches will be excavated for electrical cabling (including DC cables from the modules to the inverters and AC cables from the inverters to the switch house yard). Trenches will typically be 1 m deep by 0.5 m wide and will be excavated using a 'ditch-witch' plough, backhoe or similar equipment. Trenches will have a sand base layer below and above the cabling, and once the cabling is laid, the trenches will be backfilled and levelled to match the existing grade. Where necessary, high density polyethylene (HDPE) conduits will be installed beneath road crossings and in areas of shallow bedrock to house and protect the cables.

3.6.1.8 *Switch House Yard Construction*

The switch house yard will be located in the southeast corner of the Project Location (Figure 2.1). Construction will include excavation of topsoil, installation of ground grid, foundation construction, covering the area with crushed stone, and installation of electrical equipment. Switchgear, protection and control equipment will be housed in a prefabricated, weatherproof switch house building enclosure. The switch house will be trucked to the site and installed on a precast concrete pad. A switch house transformer is not required for the Project since the Project will connect to the existing Norfolk Power Inc. (NPI) 27.6 kV local distribution line.

3.6.1.9 *Electrical Distribution Line Installation and Interconnection Point*

Connecting to the existing NPI 27.6 kV distribution line along Stone Quarry Road will require about 40 m long overhead 27.6 kV distribution line be constructed between the Project switch house yard and the point of interconnection (POI) with the NPI distribution line (Figure 2.1). The Proponent will construct the overhead distribution line from the switch house yard to the Project property line in

accordance the Ontario Electrical Safety Code. NPI will construct the section of the line from the Proponent property line to the POI.

3.6.1.10 Testing and Commissioning

Following the installation of all electrical components, testing and commissioning will be performed prior to start up and connection to the power grid. The solar modules, inverters, transformers and electrical cables will be checked for system continuity, reliability and performance. If problems or issues are identified, remedial corrections will be made prior to start up.

3.6.1.11 Site Restoration

Site restoration will occur during and following the final stages of the Project construction and installation activities. The main objective will be to stabilize and re-instate vegetation within all areas disturbed by the Project construction. Site restoration will include the removal of all construction material, equipment, temporary facilities and waste from the Project Location. Topsoil will be redistributed where required, followed by finished grading and landscaping to achieve proper drainage. Re-vegetation will include planting of native plants and hydro-seeding where required.

3.6.2 Operation and Maintenance

3.6.2.1 Operation

The Project will operate year round and generate electricity during daylight hours. The amount of power generated will depend on daily weather conditions and sufficient solar irradiation. The Project will be operated remotely and does not require a permanent on-site operator. Any damage or faults with the PV modules and electrical systems will be alerted to staff remotely and repaired (or replaced) by facility staff or qualified professionals. To ensure the safety and integrity of the Project facilities, access to the site will be limited to Project personnel and unauthorized public access to the site will be prevented by fences, gates and security procedures.

A Project Facility Manager, appointed by the Proponent will be responsible for the day-to-day management of all Project facilities, including supervising site activities, site inspections, facility maintenance and repair. The Project Facility Manager, or his/her designate and/or other Proponent staff will be responsible for staff training, health and safety training and compliance, environmental regulatory compliance and public/municipal communications. For general monitoring and site maintenance purposes, two part time or full-time local personnel would be dispatched from a central operations office as needed. Proper health and safety procedures for on-site maintenance personnel will be implemented as per provincial and federal regulations.

Operationally, there are no significant hazards involved in the operation of the Project, nor are hazardous materials stored on the site or created by the Project during its operation. The Project will not generate significant quantities of waste from its operation nor will the Project generate any wastewater (sewage) or discharge any liquid effluent from its operation.

Project operation will not result in the discharge of contaminants or pollutants to the air. The only noise emissions associated with the Project operation will be from the inverters and pad-mounted transformers, which will only operate during daylight hours. A Noise Study Report (Hatch, 2011j) involving computer modeling simulations of the Project has confirmed that the applicable Ministry of Environment noise level limits will not be exceeded at the locations of the nearest noise receptors.

Sound level monitoring, if required by MOE, as a condition in the REA for the Project will be implemented and annual compliance reports submitted to the MOE. In addition, the Proponent will use feedback obtained from nearby noise receptors to confirm that noise emissions are within reasonable levels.

The Project operation will not result in significant visual disturbance due to reflectivity from the solar PV modules. A Reflectivity Study (IBI, 2011) has determined that most reflection from the modules will be directed upwards above the height of most vehicles and residents in the area. The only exception to this would be at sunrise and sunset, when light may be reflected horizontally from the panels. These conditions would only be present at specific viewing locations (e.g. Stone Quarry Road) between March and September and the duration of the impact would be between 10 to 15 minutes (IBI, 2011). The presence of the 2.7 m high security fence along the south side of the Project Location will effectively mitigate any effects along Stone Quarry Road. Any other areas of potential human impact will be identified and screened with a minimum 1.2 m high vegetation barrier.

3.6.2.2 *Site Inspection and Maintenance*

The Project solar PV modules, inverters and transformers and other electrical equipment, wiring and electrical connections will be routinely inspected, typically on a monthly basis. Any broken or malfunctioning PV modules, electrical cabling or components will be repaired or replaced by facility staff. Trash, debris and equipment parts replaced during maintenance and repair activities will be collected and properly stored in waste disposal bin(s). All waste collected during operation of the Project will be removed from the site in accordance with provincial and municipal requirements.

The Project site grounds including vegetation coverage, drainage systems and trees will be monitored and maintained regularly. Since suitable ground cover will be established under the PV modules, some form of vegetation abatement such as grass cutting may be required several times throughout the summer months. No hazardous chemicals would be used for this vegetation control.

The site, including any constructed drainage features (e.g. grassed swales, culverts) and any sediment and erosion control measures (e.g. rip rap protection, rock flow checks) will be visually inspected for any signs of erosion or sedimentation and recorded in a log book. Regular maintenance such as the cleanout of accumulated sediment and/or the removal of any debris blockage would be conducted at that time. If required, remedial works (e.g. stabilizing and/or reseeding of identified erosion areas) and repairs to any drainage features or sediment and erosion control measures will be implemented to prevent environmental impacts.

The need to clean the solar PV modules will be determined according to local weather conditions, such as the quantity and frequency of rain and snow at the Project Location. At the very most, it is expected that the modules will require cleaning quarterly, but it is possible that cleaning the modules will not be necessary at all. If required, water trucks will bring water to the site to supply the water required. No chemicals will be used for the cleaning of the modules.

The transformers will be visually inspected on a monthly basis and their status recorded in a log book. Any faulty equipment that could result in an oil leak will be repaired and any observed leaks will be cleaned up immediately by maintenance personnel. Spill response equipment will be left on site or in the maintenance trucks should leaks be observed.

During winter, Project access roads will be ploughed to clear snow to maintain access of personnel to Project facilities. Under most winter conditions, snow is expected to melt due to the module heating and the 30° tilt. Under some conditions, manual snow removal may be performed by maintenance personnel who will clear the snow using a brush attached to a long pole.

3.6.2.3 Storm Water Management

Drainage works including grassed swales, ditches and roadside culverts will be designed and constructed as part of the facility civil components. Overall, major alteration to the existing surface drainage patterns is not expected as part of the Project's construction and operation. A conceptual storm water management study has been prepared for the Project (McIntosh Perry, 2011a) which confirmed that only a minor increase in runoff peak flows would occur as a result of the Project and that implementation of storm water mitigation measures would ensure that runoff from the Project Location will not exceed existing condition levels.

The following storm water management practices will be implemented to ensure that significant negative environmental effects to existing drainage conditions (e.g., increased runoff, erosion) will not occur as a result of the Project:

- Existing drainage patterns within the Project Location will be maintained to the extent possible and/or as required to maintain the common law drainage rights of upstream or downstream riparian landowners. Following construction, the entire Project Location, with the exception of the access roads, will be re-vegetated with native grass or other suitable ground cover to promote surface water infiltration, filter storm water runoff and to prevent erosion.
- New drainage swales and channels will be constructed as enhanced (flat-bottom) grassed swales to provide extended flow times, filtering of runoff and reduce the potential for erosion. Small concrete weirs will be constructed within the drainage swales to provide temporary storage of storm water runoff to control the post-development runoff peak flows to pre-development levels (McIntosh Perry, 2011a).
- The vehicle parking area for maintenance personnel and all interior access roads will be constructed with gravel to promote infiltration and reduce the quantity of storm water runoff.
- Rainfall runoff from the solar modules, inverter building rooftops, transformer concrete pads (if not enclosed in the inverter building), interior roads and parking area will be directed to grassed or vegetated areas, a minimum of 15-m wide, to promote infiltration and filtering of runoff by vegetation prior to its conveyance to on-site grassed swales.
- All transformers will use an organic based vegetable oil (e.g., BIOTEMP®, Envirotemp® FR3™), which is non-toxic, non-bioaccumulating and readily biodegradable in the environment. All transformers will be routinely inspected and any faulty equipment that could result in an oil leak will be repaired. Spill response equipment will be left on site and any observed leaks will be cleaned up immediately by maintenance personnel.

3.6.2.4 Water Supply Facilities

The Project does not require any on-site facilities to supply groundwater (wells) or surface water (ponds, watercourses) for operation of the Project. It is anticipated that water from rain and snow will

be sufficient for cleaning the solar PV modules; if not, the Proponent will contact local suppliers to provide water in tankers from off-site sources for this purpose. No chemicals will be used in the cleaning of the PV models.

3.6.2.5 *Wastewater (Sewage) Facilities*

The Project will not generate any wastewater (sewage) or discharge any liquid effluent from its operation nor does the Project require any on-site facilities for the collection, transmission, treatment or disposal of wastewater for operation of the Project. During operation, since only two persons will work at the Project on an intermittent basis, sanitary facilities (e.g. permanent washrooms with a septic disposal system) are not required. If sanitary facilities are determined to be required, portable toilets, provided and serviced by a local sanitation company, will be used.

3.6.2.6 *Waste Disposal Facilities*

The Project will not generate significant quantities of waste from its operation. A small waste disposal bin(s) will be provided on site to collect any trash, debris or equipment parts replaced during routine maintenance of the Project during its operation. Periodically, when required, the Proponent will arrange for a licensed waste disposal company to empty the bins and haul the waste to an appropriate waste disposal facility off-site.

3.6.2.7 *Exhaust Equipment*

The Project has no facilities or equipment that will discharge contaminants or pollutants to the air (e.g. exhaust gases from emergency back-up diesel generators) during operation of the Project.

3.6.3 ***Decommissioning***

It is anticipated that the Project equipment will have a useful lifetime of at least 20 years, which can be extended up to 30 years or more with proper maintenance, component replacement and repowering. If at the end of the 20-year power purchase agreement with the Ontario Power Authority the Project owner decides not to continue operation of the Project, the Project will be decommissioned. If so, the Project owner will ensure that the Project Location is restored back to its pre-construction condition agricultural crop land use or as may be appropriate at that time.

The decommissioning process would typically involve the following:

- Removal of the solar modules for reuse in another location if possible. Otherwise, the glass and silicon will be reclaimed and the aluminum frames will be recycled.
- Removal of the scrap metal and cabling. Where possible, these materials will be recycled, with non-recyclables taken to an approved disposal site.
- Removal of support structures and foundations unless the landowner requests otherwise. These materials will be recycled where possible.
- Site restoration and regrading and, if necessary, restoration of surface drainage swales and ditches.
- Planting of leguminous crops and/or other native vegetation as appropriate to provide a rapid return of nutrients and soil structure.

4. Description of Environmental Effects

4.1 General

This section summarizes the potential negative environmental effects that may result from the Project, including its construction, operation and decommissioning. With the exception of transporting construction materials and the workforce to and from the Project Location, all construction and operational activities will occur at the Project Location. However, potential environmental effects have been considered within 300 m of the Project Location.

Figure 2.1 depicts the Project components and the various natural heritage, water body and other features on and within proximity to the Project Location. Setback distances from identified significant natural heritage features and waterbodies are also shown.

Information presented herein, including the existing cultural heritage, natural heritage, water body, socio-economic and other features, and potential environmental effects has been summarized from the following documents:

- Natural Heritage Assessment Records Review Report (Hatch, 2011a)
- Natural Heritage Assessment Site Investigation Report (Hatch, 2011b)
- Natural Heritage Assessment Evaluation of Significance Report (Hatch, 2011c)
- Natural Heritage Assessment Environmental Impact Study (Hatch, 2011d)
- Water Body Records Review Report (Hatch, 2011e)
- Water Body Site Investigations Report (Hatch, 2011f)
- Construction Plan Report (Hatch, 2011g)
- Design and Operations Report (Hatch, 2011h)
- Decommissioning Plan Report (Hatch, 2011i)
- Noise Study Report (Hatch, 2011j)
- Stage 1 and 2 Archaeological Assessment Report (TAI, 2010)
- Geotechnical Investigation Report (GENIVAR, 2011)
- Storm Water Management Report (McIntosh Perry, 2011a)
- Traffic Impact Study Report (McIntosh Perry, 2011b)
- Phase I Environmental Assessment Report (McIntosh Perry, 2011c)
- Proposed Groundwater Monitoring Scoping Report (McIntosh Perry, 2011d)
- Reflectivity Study Report (IBI, 2011).

4.2 Environmental Resource Features and Potential Effects

The following provides a summary discussion of the identified environmental resource features on and within proximity of the Project Location along with references of the specific REA report(s) where this information was obtained from.

Table 4.1 summarizes the identified potential negative environmental effects associated with the Project's construction, operation and decommissioning phases along with the recommended mitigation measures to ensure that no significant residual negative environmental effects will occur as a result of the Project.

4.2.1 Heritage and Archaeological Resources

The Project is not located on a protected property (e.g. cultural heritage property designated under the *Ontario Heritage Act*) as defined in Column 1 of the Table in Section 19(1) of O. Reg. 359/09. In addition, research and consultation with the municipality and completion of the Ministry of Tourism and Culture (MTC) – *Check Sheet for Environmental Assessments: Screening for Impacts to Built Heritage and Cultural Heritage Landscapes* has determined that there is no need to conduct a heritage impact assessment for the Project under Section 23 of O. Reg. 359/09.

Stage 1 and 2 Archaeological Assessments were completed by The Archaeologists Inc. in 2010 and a report (TAI, 2010) was submitted to the Ministry of Tourism and Culture (MTC). No archaeological resources were found as part of the Stage 1 and 2 archaeological study and the assessment concluded that the Project Location can be considered free of any archaeological concerns. The report was submitted to the MTC and a Letter of Confirmation dated November 22, 2010 was obtained from the MTC confirming their agreement and acceptance of the findings of the archaeological assessments.

4.2.2 Natural Heritage Resources

Natural heritage resources on and within 300 m of the Project Location are shown in Figure 2.1.

There are no provincially significant wetlands, valleylands, provincial parks, conservation reserves or Areas of Natural and Scientific Interest (ANSIs) on or within 120 m of the Project Location (Hatch, 2011a, b).

There is a woodland about 40 m southwest of the Project Location. This woodland was assessed as a significant woodland and provides significant wildlife habitat for the Red-headed Woodpecker, a species of conservation concern (Hatch, 2011c). Under the REA Regulation, an environmental impact study (EIS) is required for Project facilities proposed within 120 m of significant woodlands or significant wildlife habitat. Based on the assessment finding of the EIS, construction and operation of the Project will not result in significant adverse impact to this feature (Hatch, 2011d). As such, no specialized mitigation measures or setbacks from this feature are required for the Project.

There is a restored tallgrass prairie vegetation, a provincially rare vegetation community about 40 m southwest of the Project Location. This feature was assessed as providing significant wildlife habitat for area-sensitive grassland/agriculture bird species (e.g. Eastern Meadowlark, Grasshopper Sparrow, Savannah Sparrow, etc.) (Hatch, 2011c). Under the REA Regulation, an EIS is required for Project facilities proposed within 120 m of significant wildlife habitat. Based on the assessment finding of the EIS, construction and operation of the Project will not result in significant adverse impact to this

feature (Hatch, 2011d). As such, no specialized mitigation measures or setbacks from this feature are required for the Project.

A Natural Heritage Assessment Environmental Impact Study was conducted to assess potential adverse effects and required mitigation and monitoring measures for the above noted significant natural heritage features on and within 120 m of the Project Location. This report along with the other Natural Heritage Assessment Reports were submitted to the Ministry of Natural Resources (MNR) Aylmer District Office. A Letter of Confirmation was obtained on May 19, 2011 from the MNR confirming their agreement and acceptance of the findings and recommendations of the Natural Heritage Assessment Reports.

Potential adverse effects on significant natural heritage features and other (non-significant) natural features are summarized in Table 4.1. Additional information potential effects and mitigation is provided in the Construction Plan Report (Hatch, 2011g), the Design and Operations Report (Hatch, 2011h) and the Natural Heritage Assessment Environmental Impact Study Report (Hatch, 2011d).

4.2.3 Waterbodies

Water body features (e.g., permanent and intermittent streams, lakes, seepage areas) on and within 300 m of the Project Location are shown in Figure 2.1.

There are no waterbodies on or within 120 m of the Project Location nor are there any lake trout lakes at development capacity within 300 m of the Project Location (Hatch, 2011f). The nearest water body is Davis Creek about 600 m northwest of the Project Location. This feature does not pose a constraint to the Project since it is located greater than 120 m from the Project Location. There is a small manmade dugout pond west of the Project Location (Hatch, 2011f). According to the definition of “water body” within the REA Regulation, dugout ponds are not waterbodies and therefore, no defined setback is required for the Project from this feature.

As discussed in Section 3.6.2.3, a storm water management study (McIntosh Perry, 2011a) was conducted to assess existing and proposed runoff peak flows from the Project and identify any required mitigation. The study concluded that that construction and operation of the Project would not result in significant increases to runoff peak flows and that following the implementation of storm water quantity control measures, runoff from the Project will be similar to existing conditions once the site has been restored and the ground cover has re-established.

An assessment of potential adverse effects to groundwater resources (i.e., groundwater quality and quantity), including potential impacts due to dewatering of construction excavations, installation of the support foundations and accidental spills, was conducted based on the findings of the Geotechnical Investigation Report (GENIVAR, 2011). No significant adverse impacts to groundwater conditions were identified for the construction, operation and decommissioning of the Project. A groundwater monitoring program has been developed (McIntosh Perry, 2011d) which will involve well water quality monitoring within the Project Location and in select local domestic wells prior, during and following construction to assess any potential changes. The findings will be reported to MOE and participating well owners.

Potential adverse effects on waterbodies (i.e., surface water features and drainage conditions) and groundwater resources are summarized in Table 4.1. Additional information on potential effects and

mitigation is provided in the Storm Water Management Report (McIntosh Perry, 2011a), the Construction Plan Report (Hatch, 2011g) and the Design and Operations Report (Hatch, 2011h).

4.2.4 Air, Odour and Dust

Potential adverse effects on air quality due to vehicle emissions and potential fugitive dust emissions during construction, operation and decommissioning are summarized in Table 4.1. Additional information on potential effects and mitigation is provided in the Construction Plan Report (Hatch, 2011g) and the Design and Operations Report (Hatch, 2011h).

4.2.5 Noise

Potential adverse effects on nearby noise receptors during construction of the Project are summarized in Table 4.1. The only noise emissions associated with the Project operation will be from the inverters and pad-mounted transformers, which will only operate during daylight hours. The locations of the inverters and transformers within the Project Location have been designed to minimize off-site effects to nearby noise receptors (Figure 2.1). A Noise Study Report (Hatch, 2011j) involving computer modeling simulations has confirmed that the applicable Ministry of Environment noise level limits will not be exceeded at the locations of the nearest noise receptors.

4.2.6 Land Use and Resources

Land uses and resources on and within 300 m of the Project Location are shown in Figure 2.1.

The Project Location has historically been used for, and is currently used for, agricultural crops. There are no water wells on the Project Location and there are no municipal potable water services or sewer services supplying the Project Location (McIntosh Perry, 2011c). A non-operational underground Bell Canada communication cable(s) is present within the eastern portion of the Project Location (Figure 2.1). An existing overhead electrical distribution line is present within the western portion of the Project Location. There are no building within the Project Location other than a small pump house located in the west-central portion of the Project Location (McIntosh Perry, 2011c).

Land uses adjacent to the Project Location are active agriculture lands and associated farmsteads and rural residential dwellings present along Stone Quarry Road and Cloet Road. Norfolk Power Inc. (NPI) 27.6 kV distribution line is situated south of the Project Location along Stone Quarry Road. An existing 93 m high Rogers cellular tower is present west of the Project Location. No potential negative effect on the telecommunications network is anticipated due to Project. There are no known aggregate resources, landfill sites, petroleum wells or recreational areas on or within 300 m of the Project Location.

The Project Location and adjacent lands are designated Agricultural in the Norfolk County Official Plan (2006) (Schedule A-1). Special zoning provisions to allow solar farming for the Project Location lands within the County's Agricultural land use designation were approved by Norfolk County Council in April 2009.

A Phase I Environmental Site Assessment (ESA) was conducted for the Project by McIntosh Perry (2011c) that provided a qualitative assessment of the environmental condition of the Project Location lands based on published records (e.g., land title, historical aerial photographs), landowner interviews and a site reconnaissance. Although the study found no direct evidence of contamination

of the Project Location from past land uses, several areas of potential environmental concern (e.g. above ground storage tank) were identified by the study along with mitigation and/or improvement measures to address such concerns (McIntosh Perry, 2011c).

Potential adverse effects on availability of resources and current land uses during construction, operation and decommissioning are summarized in Table 4.1. Additional information on adverse effects and mitigation is provided in the Construction Plan Report and the Design and Operations Report (Hatch, 2011h).

4.2.7 Provincial and Local Infrastructure

Provincial and local infrastructure identified within 300 m of the Project Location include:

- Municipal roads and associated rights of ways include Stone Quarry Road immediately south of the Project Location and Cloet Road west of the Project Location.
- A Norfolk Power Inc. (NPI) 27.6 kV electrical distribution line is situated south of the Project Location along Stone Quarry Road. The Project will connect to this line.
- An existing 93 m high Rogers cellular tower is present west of the Project Location. This tower may create some shading effects, but otherwise it does not pose a constraint to the Project.
- A non-operational underground Bell Canada communication cable(s) is present within the eastern portion of the Project Location. This cable will be removed prior to Project construction.
- An existing overhead electrical distribution line is present within the western portion of the Project Location. This line will be relocated prior to construction of the Project.

A Traffic Impact Study (McIntosh Perry, 2011b) has assessed the potential traffic-related impacts on local roads during construction, operation and decommissioning of the Project. The study concluded that the Project will have a negligible impact (i.e., delays to local community traffic flow) to the surrounding road network given the low anticipated vehicle trips generated by the Project, as well as the low existing traffic volumes. The study also noted that some minor damage could occur to local roads as a result of heavy construction vehicles, but that Axio/SunEdison will work with the municipality to address any damage if it was to occur.

Potential adverse effects on provincial and local services and infrastructure (i.e. impacts to local traffic and roads) during construction, operation and decommissioning are summarized in Table 4.1. Additional information on potential effects and mitigation is provided in the Construction Plan Report (Hatch, 2011g) and the Design and Operations Report (Hatch, 2011h).

4.2.8 Public Health and Safety

Potential adverse effects on public health and safety during construction, operation and decommissioning are discussed in Table 4.1. Additional information on adverse effects and mitigation is provided in the Construction Plan Report (Hatch, 2011g) and the Design and Operations Report (Hatch, 2011h).

4.2.9 Areas Protected Under Provincial Plans and Policies

The Project Location is not located within any of the following Provincial Plan areas:

- Protected Countryside or Natural Heritage System of the Greenbelt Plan and *Greenbelt Act*
- Oak Ridges Moraine Conservation Plan Area
- Niagara Escarpment Plan Area
- Lake Simcoe Watershed Plan Area.

4.3 Summary

Solar energy is a clean, zero emissions renewable energy resource that the Ontario Government is investing in to eliminate coal fired generation and help mitigate climate change. A 10 MW solar project can conservatively provide enough power for approximately 1,200 homes a year, and will generate power during times of the day when it is needed most. Unlike many forms of traditional power generation, solar facilities have a minimal impact on the land because there are no permanent structures left on-site after decommissioning. Preferred sites are already disturbed or industrial lands, or agricultural lands with poor soil types. Furthermore, soil conditions are not affected, and could improve over time. Drainage is managed on the site to maintain existing runoff conditions and minimize erosion.

Based on the findings of the various assessment studies conducted as part of this REA application (as noted in Section 4.1) and the proposed mitigation measures identified (as summarized in Table 4.1), no significant adverse residual environmental effects are expected to occur as a result of the Project construction, operation and decommissioning.

Table 4.1 Summary of Potential Negative Environmental Effects during Construction, Operations and Decommissioning

Environmental Component	Project Phase	Sources of Negative Effect	Potential Negative Effect	Mitigation Measures	Residual Negative Effect
Natural Environment Components					
Soil Quality	Construction and Decommissioning	Soil compaction from heavy equipment, construction vehicles and/or stockpiling of heavy materials.	Soil compaction resulting in changes to soil structure which could cause decreased productivity for plant growth, reduced infiltration and increased runoff.	Project Location will be assessed for compaction following construction and decommission activities. Areas of significant compaction will be restored using mechanical discing or other soil loosening methods.	No residual effect given effective mitigation.
Soil Quantity	Construction, Operations and Decommissioning	Wind and/or water erosion of soils within the Project Location.	Loss of soils from the Project Location, potentially affecting other environmental components (e.g., air quality, vegetation, surface water quality).	Sediment and erosion controls installed and maintained during construction and decommissioning. Dense non-invasive vegetation ground cover planted throughout disturbed areas of the Project Location following construction. Drainage features with erosion protection (e.g., grass lined, rip rap protection) during operations.	No residual effect given effective mitigation.
	Construction and Decommissioning	Topsoil stripping for access roads, laydown, parking area, switch house yard and inverter/transformer building pads.	Loss of the quantity of topsoil resulting in reduced productivity of the soil to support vegetation growth.	Stripped topsoil will be stockpiled on-site for use during site restoration after construction. Following decommissioning, topsoil previously stripped will be replaced to facilitate revegetation. If necessary, topsoil will be brought in from off-site sources.	Some minor loss of topsoil anticipated due to stripping during construction.
Groundwater	Construction and Decommissioning	Installation (i.e., construction) or removal (i.e., decommissioning) of support foundations (e.g. driven or screwed steel piles) into the ground to support the PV modules and racks.	No adverse effects on groundwater quantity or quality are expected since driven/screw piles do not require soil excavation and will not affect groundwater recharge conditions due to small area of supports relative to Project Location.	The Proponent will conduct well water quality monitoring within the Project Location and in selected local residents' domestic wells before and after construction to assess any potential changes. The findings will be reported to MOE and participating well owners.	None.
	Construction	Dewatering of excavations for foundations for inverter/transformers and trenching for electrical cabling to keep the work area dry.	No adverse effect on water table or nearby water wells since significant pumping of groundwater is not required. Some pumping of rainwater out of excavations may occur.	If pumping is required, water will be discharged to a heavily vegetated area or pumped through a filtration bag so that turbid water is not discharged directly to receiving watercourses.	No residual effect given effective mitigation.
	Operation	Decreased groundwater recharge (i.e., infiltration) due to addition of impervious (e.g. inverter buildings) and less pervious areas (e.g. gravel roads).	No adverse effect on groundwater recharge conditions is expected since the amount of impervious and less impervious areas is small.	Dense vegetation cover beneath solar modules and around Project components to promote infiltration and maintain soil moisture conditions will help offset minor reduction in infiltration due to addition of impervious and less impervious areas.	No residual effect given effective mitigation.
Surface Water Quantity	Construction, Operations and Decommissioning	Alteration of existing topography and surface drainage patterns from earth grading and excavation activities. Runoff from impervious (e.g. inverter buildings) and less pervious areas (e.g. gravel roads). Installation of new drainage swales, ditches and culverts.	Minor increase in surface water runoff from Project Location to off-site receiving drainage swales, ditches and/or watercourses resulting in erosion (McIntosh Perry, 2011a). Potential adverse effects to receiving water quality due to increased turbidity in runoff due to soil erosion.	Maintain existing drainage patterns as much as possible. No construction of Project facilities within 120 m of a watercourse unless EIS is prepared. Retain and/or plant dense vegetation as soon as possible following construction. Sediment and erosion controls installed and maintained during construction and decommissioning. Storm water management measures installed to control increases in runoff peak flows from the Project Location to pre-development levels.	No residual effect given effective mitigation.
	Operations	Washing of solar panels during maintenance activities.	Minor increase in surface water runoff from the Project Location if all of the wash water does not infiltrate into the underlying soils.	Amount of water used for cleaning will be limited to the extent possible. Natural infiltration of wash water into underlying soils and storm water management measures will prevent any adverse off-site increase in runoff.	No residual negative effects anticipated. Washing of panels during summer will be positive benefit to vegetation and subsoils beneath the solar panels.
Surface Water Quality	Construction, Operations and Decommissioning	Wind and/or water erosion of soils within the Project Location.	Erosion of soils from the Project Location could result in adverse effects on surface water quality in receiving waterbodies, with associated effects on aquatic biota and habitat.	Sediment and erosion controls installed and maintained during construction and decommissioning. Dense non-invasive vegetation ground cover planted throughout disturbed areas of the Project Location following construction. Drainage features with erosion protection (e.g., grass lined, rip rap protection) during operations.	No residual effect given effective mitigation.
	Operations	Washing of solar panels during maintenance activities.	Adverse effects on the quality of the water running off the panels if cleaning agents used.	Rainfall is expected to be sufficient for cleaning purposes otherwise water will be brought on-site. If water from off-site is required, the amount used will be less than that occurring during a normal rainstorm event. No cleaning solutions will be used.	No residual effect given effective mitigation.

Environmental Component	Project Phase	Sources of Negative Effect	Potential Negative Effect	Mitigation Measures	Residual Negative Effect
		Runoff of herbicide residue if used to control vegetation.	Adverse effects on surface water quality due to potential use of herbicides to control vegetation communities.	Vegetation will be properly managed and maintained using mechanical methods (grass mowing, tree branch trimming); no chemical herbicides will be used for vegetation control. Some very limited herbicide use may be required to control weeds around electrical equipment and if so, in accordance with all local and provincial procedures.	No residual given effective mitigation.
Aquatic Habitat and Biota	Construction, Operations and Decommissioning	Erosion, increases in surface water runoff, accidental spills on Project Location.	Indirect effects to aquatic habitat and biota in receiving watercourses (e.g., Demorestville Creek) due to increased turbidity in runoff, sedimentation or accidental spills.	Mitigation measures for Soils, Surface Water and Spills will mitigate any potential adverse impacts to aquatic features located on or off-site.	No residual effect given effective mitigation.
Woodlands	Construction	Clearing of agricultural crop land and selected trees within the Project Location.	No adverse impacts since vegetation is non-significant. Some minor potential for damage to adjacent trees/shrubs and/or disturbance to the rooting zone through soil compaction. Increased surface water and soil erosion, and potential indirect effects to receiving water quality due to vegetation removal.	Work areas will be demarcated in order to ensure that the Contractor does not work beyond those bounds. Soil loosening methods for compacted soils. Dense non-invasive vegetation ground cover planted throughout disturbed areas of the Project Location. Mitigation measures for: Soils and Surface Water will minimize potential for increased runoff and erosion.	No residual effect given effective mitigation.
		Generation of airborne dust from construction activities.	Indirect effects to adjacent off-site significant woodlands north and east of Project Location could include deposition of dust on leaves.	Mitigation measures for: Air Quality and Soils will minimize generation of airborne dust to adjacent off-site vegetation communities.	Minor potential for residual effect associated with generation of airborne dust from exposed soils during construction activities that occur on extremely windy days.
Wildlife Habitat	Construction and Operations	Clearing of agricultural crop land and selected trees within the Project Location. Presence of Project components and long-term alterations in habitat conditions on Project Location.	Minor loss of non-significant wildlife habitat associated with agricultural fields. No adverse effects on the form and function of the woodland or tallgrass prairie habitats 40 m southwest of the Project Location. Altered wildlife habitat use within the Project Location.	Work areas will be demarcated in order to ensure that the Contractor does not work beyond those bounds. Retain and/or plant dense vegetation ground cover beneath solar panels to provide wildlife habitat for bird, reptile and small mammal species. Sediment and erosion controls and storm water management measures will prevent adverse effects off-site effects to wildlife habitats.	Long-term wildlife use of the Project Location will be altered, but no overall change in local composition or population is anticipated to occur. No residual negative effects to off-site wildlife habitats.
Wildlife	Construction and Decommissioning	Clearing and/or alteration of vegetation within the Project Location. Use of heavy equipment and presence of workforce. Construction vehicles travelling on access roads within Project Location.	Avoidance of Project Location by wildlife due to equipment, noise and human presence. Possible noise disturbance to breeding birds in woodland and tallgrass prairie 40 m southwest of Project Location. Incidental take of wildlife due to construction vehicles within Project Location.	Construction scheduling of significant noise generating activities to avoid peak hours of breeding bird singing (approximately one half hour before sunset to approximately 8:30 am) during the breeding bird period (generally May through July). Daily visual monitoring of construction work areas prior to start or work. Speeds on Project access roads will be restricted. Construction workforce will be alerted to the potential for wildlife and that measures should be taken to avoid wildlife wherever possible.	Minor periodic disturbance of local wildlife. No long-term effects on species composition or local populations anticipated. Mitigation will effectively reduce risk of incidental take of wildlife, but not completely eliminate.
	Construction	Installation of perimeter fencing around the Project Location.	Trapping of wildlife within the Project fence.	Prior to fence completion, a visual search of the area within the fence will be completed. If species are observed, they will be directed off the Project site or collected by a designated employee using approved handling protocols and transported to the nearest available location off-site and released.	No long term residual effect on wildlife.
	Operations	Maintenance vehicles and activities (e.g. grass cutting) and installation of the fence around the Project Location.	Disturbance of wildlife due to maintenance equipment noise and human presence resulting in wildlife avoidance of Project Location. Restricted wildlife movement across Project Location due to fence. Incidental take of wildlife due to maintenance vehicles or	Vehicle speeds on Project access roads will be restricted. Maintenance workforce will be alerted to the potential for wildlife and that measures should be taken to avoid wildlife wherever possible. If wildlife are observed on the Project Location, they will be either directed off of the site or collected by a designated employee using approved handling procedures released off-site. If possible, maintenance activities (e.g.	Minor potential for incidental take of wildlife due to maintenance vehicles or vegetation mowing. Overall, disturbance to wildlife due to maintenance activities is expected to be

Environmental Component	Project Phase	Sources of Negative Effect	Potential Negative Effect	Mitigation Measures	Residual Negative Effect
			activities (e.g. grass cutting).	grass cutting) to avoid breeding bird season of ground nesting birds May through early July).	less than existing disturbance due to agricultural activities.
Socio-Economic Environmental Components					
Air Quality	Construction and Decommissioning	Generation of airborne dust from land clearing and excavation activities, vehicle travel on dirt roads and exhaust emissions from construction vehicles and equipment.	Reductions in local air quality from airborne dust and exhaust emissions from construction vehicles and equipment.	Construction practices to suppress dust (e.g., limit soil exposure, road watering, stabilize and cover stockpiles) and restrict soil working activities during windy conditions. Contractor to ensure that all construction vehicles and equipment have properly functioning emission controls (e.g., mufflers and no excessive vehicle idling).	Some short term minor effects on local air quality due to fugitive dust generation and vehicle emissions.
	Operations	Emissions from Project operations and maintenance vehicles.	Project operation will not discharge any pollutants into the air and emissions from maintenance vehicles or equipment (e.g. grass mowers) will be negligible.	None required.	None.
Noise	Construction and Decommissioning	Noise emissions from construction vehicles and equipment use.	Disturbances to nearby sensitive receptors (i.e., houses and institutions) due to noise emissions.	Contractor to comply with municipal Noise Control By-Laws for construction working times and ensure that vehicles and equipment have proper functioning sound baffling equipment (e.g., mufflers). Notification to adjacent noise receptors to report noise complaints.	Possibly, some short-term, temporary 'nuisance' disturbance to sensitive nearby noise receptors during certain construction activities.
	Operations	Noise emissions from transformers and inverters and/or from maintenance vehicles or equipment (e.g. grass movers).	Disturbances to nearby sensitive receptors (i.e., houses and institutions) due to noise emissions.	Inverters and transformers will be housed in a building enclosure that will provide mitigation of noise emissions from this equipment. Proponent will conduct auditory monitoring and obtain feedback from nearby noise receptors to confirm that noise emissions are within reasonable levels. Facility personnel to ensure maintenance vehicles and equipment have proper sound baffling equipment (e.g., mufflers) and work is done in compliance with municipal Noise Control By-Law.	Noise emissions will meet Ministry of Environment's requirements for rural area sound levels of 45 dBA for day time and 40 dBA for night time at the nearest noise receptors.
Public and Facility Safety	Construction, Operations and Decommissioning	Construction or facility equipment malfunction, fire or accidents resulting in injury to public, construction workers or facility maintenance personnel.	Personal injury to the public if trespassing on-site or to construction workers or facility maintenance personnel due to accidents, fire or equipment malfunction.	Public access to the facility will be prevented through the use of fences, gates, and any other necessary security procedures. Proper health and safety procedures for construction workers and facility maintenance personnel will be implemented as per provincial and federal regulations.	No risk to public safety unless trespassers obtain access to the site. Health and safety procedures will reduce risk of personal injury to construction workers and facility maintenance personnel, but some risk from accidents will remain.
Traffic and Municipal Roadways	Construction and Decommissioning	Construction vehicles and workforce commuters travelling to and from the Project.	No significant traffic-related impacts identified based on Traffic Impact Study (McIntosh Perry, 2011b). Heavy construction vehicles may damage local roadways.	Prepare transportation route plan and implement construction scheduling as required to avoid bottlenecks of equipment deliveries to site. Construction flag-person to direct vehicles into and out of the site. Municipal 'half-load' requirements for roads will be adhered to. Any damage to local roadways will be repaired by the Contractor.	None.
	Operations	Facility operation and maintenance personnel to and from the Project.	None. The number and frequency of facility personnel travelling to the Project is negligible (McIntosh Perry, 2011b).	None required.	None.
Archaeological Resources	Construction	Excavations for foundation construction and trenching for underground electrical cables.	Potential for adverse effects to undiscovered buried archaeological resources not observed during the Stage 2 Archaeological Assessment.	Project Location is considered clear of any archaeological resources based on completed Stage 1&2 Archaeological Assessments (TAI, 2010). If construction results in discovery of human remains or archaeological resources, work will stop and the Police and Ministry of Tourism and Culture will be notified.	None. Mitigation will be effective in preventing residual negative effects to human remains or archaeological resources if discovered during construction.
Protected Properties, Built Heritages and Cultural Heritage Landscapes	Construction	Construction and installation of Project facilities resulting in the loss (e.g. demolition of existing built structures) and/or alteration to significant cultural heritage features or landscapes.	No protected properties, as defined in Section 19(1) of O. Reg. 359/09, exist in the vicinity of the Project location. No negative effects to built heritage and cultural heritage landscapes since such features were either not present in the Project Location or potential effects (if any) were assessed as not significant.	None required.	None.

Environmental Component	Project Phase	Sources of Negative Effect	Potential Negative Effect	Mitigation Measures	Residual Negative Effect
Change in Visual Landscape	Construction and Decommissioning	Presence of construction site equipment, activities and personnel.	Portions of the facility will be visible from Stone Quarry Road, Cloet Road and from adjacent properties. This may be perceived as a negative environmental effect.	Existing vegetation along Stone Quarry and Cloet Roads, and existing hedgerows along the northern boundary of the Project Location will be maintained the extent possible during construction to provide some visual screening.	Short term change in local visual landscape during construction. Visual disturbance reduced with retention of existing vegetation.
	Operations	Presence of facility.	Portions of the facility will be visible from Stone Quarry Road, Cloet Road and from adjacent properties. This may be perceived as a negative effect.	Retain trees and vegetation along Project Location to extent possible to provide natural screening. If necessary, plant trees or shrubs or construct landscaping berms or fences to provide a visual barrier based on viability and effectiveness.	Long-term change in local visual landscape. Visual disturbance reduced with implementation of visual barriers.
Reflectivity	Operations	Reflection from solar PV modules during early morning and late day when sun is low.	Potential visual disturbance to adjacent observers along Stone Quarry Road for short periods of time under specific viewing angles between March and September (IBI, 2011).	The 2.7 m high security fence will effectively mitigate reflections along Any other areas of potential human impact will be identified and screened with vegetation, fencing or landscaping as necessary.	None.
Property Values	Operations	Presence of the Project within the local rural community and changes due to visual aesthetics and noise emissions from the site.	Installation of the facility has the potential, though unproven, to result in a change in the value of nearby properties based on aesthetic preference of potential landowners. Though subjective, the potential reduction in property values for the purpose of this assessment is considered a potential negative effect.	Mitigation measures to minimize visual disturbance to neighbouring properties and noise emissions that could potentially be audible will minimize the impact of the facility on neighbours, which will in turn, reduce impacts on property values.	Potential reduction in property values if buyers subjectively feel that the Project poses a potential impact to them.
Availability of Resources	Operations	Presence of the Project within an area identified as a potential aggregate, petroleum or mineral resource area.	None expected since these resources are not known to be present on the Project Location. If present, the impact would be a potential loss of access to these resources during the life of the Project. The future availability of the resources would not be changed.	None required.	Loss of access to potential aggregate, petroleum or mineral resources within the Project Location during the life of the Project. Actual potential to develop those resources during that time period is unknown.
Recreational Land Use	Construction, Operations and Decommissioning	Presence of the Project and associated fencing.	None expected since no recreational resources (e.g. trails) are present on the Project Location.	None required.	None.
Effects due to Accidental Spills					
Groundwater, Surface Water, Soil Quality, Vegetation, Aquatic Habitat and Biota	Construction and Decommissioning	Accidental spills or leakage of fuel, oil or hydraulic fluid from construction vehicles or equipment, on-site refuelling or storage of toxic liquids on-site.	Impairment of groundwater, soil and/or surface water quality due to contamination. Potential adverse effects to aquatic habitats and vegetation.	Proper storage and handling of toxic liquids (if used) in designated areas. Routine inspections of vehicles, equipment and storage containers. Spill control kits will be available on-site and spill response procedures implemented in the event of a spill. Contractor's personnel will be trained in spill response and reporting procedures. No construction vehicle refuelling or storage of toxic liquids on-site or within 30 m of a watercourse.	No residual effect given effective mitigation and spill response and clean-up measures if a spill occurs.
	Operations	Accidental spills or leakage of fuel, oil, hydraulic fluid, etc., from maintenance vehicles or equipment, on-site refuelling or storage of toxic liquids on-site. Accidental spills or leakage of transformer oil from a transformer.	Impairment of groundwater, soil and/or surface water quality due to contamination. Potential adverse effects to aquatic habitats and vegetation.	Facility personnel will be trained in spill response procedures. Spill control kits will be stored on-site and spill response/cleanup procedures implemented if a spill or oil leak is detected and MOE notified if required. No refuelling or storage of toxic liquids on-site within 30 m of a watercourse. Inverter transformers will sit on a concrete pad with no hydraulic connection (e.g., piping, drains) to surface or groundwater. All transformers will use an organic based oil (BIOTEMP®, Envirotemp®FR3™) that is non-toxic and biodegradable. All transformers will be inspected by facility maintenance personnel for signs of oil leakage.	None. Mitigation and procedures for transformer equipment inspection, monitoring and spill response/cleanup are anticipated to be effective in preventing residual negative effects.

5. References

GENIVAR Inc. 2011. Draft Geotechnical Investigation Report: Axio Power Canada Inc. Norfolk Bloomsburg TS Solar Project Norfolk County, Ontario.

Government of Ontario. 2010. Ontario Regulation 521/10 made under the Environmental Protection Act, Renewable Energy Approvals under Part V.0.1 of the Act. December 15, 2010 version. Printed in The Ontario Gazette: January 8, 2011. Available on-line at:
http://www.elaws.gov.on.ca/html/source/regs/english/2010/elaws_src_regs_r10521_e.htm.

Government of Ontario. 2009. Ontario Regulation 359/09 made under the Environmental Protection Act 2007, Renewable Energy Approvals under Part V.0.1. of the Act. September 8, 2009 version. Printed in the Ontario Gazette: October 10, 2009. Available on-line at: [Http://www.elaws.gov.on.ca/html/source/regs/english/2009/elaws_src_regs_r09359_e.htm](http://www.elaws.gov.on.ca/html/source/regs/english/2009/elaws_src_regs_r09359_e.htm).

Hatch Ltd. 2011a. Norfolk Bloomsburg TS Solar Energy Project Natural Heritage Assessment Records Review Report. Axio Power Canada Inc./SunEdison Canada. Niagara Falls, Ontario.

Hatch Ltd. 2011b. Norfolk Bloomsburg TS Solar Energy Project Natural Heritage Assessment Site Investigations Report. Axio Power Canada Inc./SunEdison Canada. Niagara Falls, Ontario.

Hatch Ltd. 2011c. Norfolk Bloomsburg TS Solar Energy Project Natural Heritage Assessment Evaluation of Significance Report. Axio Power Canada Inc./SunEdison Canada. Niagara Falls, Ontario.

Hatch Ltd. 2011d. Norfolk Bloomsburg TS Solar Energy Project Natural Heritage Assessment Environmental Impact Study. Axio Power Canada Inc./SunEdison Canada. Niagara Falls, Ontario.

Hatch Ltd. 2011e. Norfolk Bloomsburg TS Solar Energy Project Water Body Records Review Report. Axio Power Canada Inc./SunEdison Canada. Niagara Falls, Ontario.

Hatch Ltd. 2011f. Norfolk Bloomsburg TS Solar Energy Project Water Body Site Investigations Report. Axio Power Canada Inc./SunEdison Canada. Niagara Falls, Ontario.

Hatch Ltd. 2011g. Norfolk Bloomsburg TS Solar Energy Project Construction Plan Report. Axio Power Canada Inc./SunEdison Canada. Niagara Falls, Ontario.

Hatch Ltd. 2011h. Norfolk Bloomsburg TS Solar Energy Project Design and Operations Report. Axio Power Canada Inc./SunEdison Canada. Niagara Falls, Ontario.

Hatch Ltd. 2011i. Norfolk Bloomsburg TS Solar Energy Project Decommissioning Plan Report. Axio Power Canada Inc./SunEdison Canada. Niagara Falls, Ontario.

Hatch Ltd. 2011j. Norfolk Bloomsburg TS Solar Energy Project Noise Study Report. Axio Power Canada Inc./SunEdison Canada. Niagara Falls, Ontario.

Hatch Ltd. 2011k. Norfolk Bloomsburg TS Solar Energy Project Approvals and Permitting Requirements Document Report. Axio Power Canada Inc./SunEdison Canada. Niagara Falls, Ontario.

IBI Group (IBI). 2011. Norfolk Bloomsburg Solar Energy Project Reflectivity Study Report.

McIntosh Perry Consulting Engineers Limited (McIntosh Perry). 2011a. Conceptual Stormwater Management Report for Proposed Photovoltaic Project Norfolk, Ontario, Part of Lot 3 and 4, Concession 12 Geographic Township of Townsend, Norfolk County.

McIntosh Perry Consulting Engineers Limited (McIntosh Perry). 2011b. Traffic Impact Study Norfolk Bloomsburg Solar Photovoltaic Project, Town of Simcoe, Norfolk County.

McIntosh Perry Consulting Engineers Ltd. (McIntosh Perry). 2011c. Phase I Environmental Site Assessment, 48 Cloet Road Norfolk County, Ontario.

McIntosh Perry Consulting Engineers Ltd. (McIntosh Perry). 2011d. Proposed Groundwater Monitoring Scoping Report for a Proposed Solar Farm 48 Cloet Road, Norfolk County, Ontario.

Ministry of the Environment (MOE). 2010. Technical Bulletin One – Guidance for Preparing the Project Description Report as part of an application under O.Reg.359/09. Draft Document posted for public comment on the Environmental Registry March 1, 2010. 27 pp.

Norfolk County. 2006. Norfolk County Official Plan. May 9, 2006. Available on-line at <http://www.norfolkofficialplan.ca>. Accessed October 29, 2010.

The Archaeologists Inc. (TAI). 2010. Stage 1&2 Archaeological Assessment of Norfolk Bloomsburg TS, Part of Lots 3 and 4, Concession 12, Town of Bloomsburg, Norfolk County, Regional Municipality of Norfolk, Ontario. August 2010.



Suite 500, 4342 Queen Street
Niagara Falls, Ontario, Canada L2E 7J7
Tel 905 374 5200 ♦ Fax 905 374 1157